

Configurable KTY Temperature Transmitter DT 45600



Read these instructions before using the product and retain for future information.

DT 45600

► Before Startup



When operating the signal converter, certain parts of the module can carry dangerous voltage! Ignoring the warnings can lead to serious injury and/or cause damage!

The signal converter should only be installed and put into operation by qualified staff. The staff must have studied the warnings in these operating instructions thoroughly.

The signal converter may not be put into operation if the housing is open.

In applications with high operating voltages sufficient distance and isolation as well as shock protection must be ensured.

Safe and trouble-free operation of this device can only be guaranteed if transport, storage and installation are carried out correctly and operation and maintenance are carried out with care.



Appropriate safety measures against electrostatic discharge (ESD) should be taken during range selection and assembly on the transmitter.

► Short description

The configurable transmitter is designed for operating various KTY sensors. The measured values are converted temperature linear into a current or voltage signal.

The configuration can be done either via DIP switch or via a USB-interface with the PC configuration program DRAGOset. A wide variety of standard measuring ranges are available ready to use.

The 3-way isolation guarantees reliable decoupling of the sensor circuit from the processing circuit and prevents linked measurement circuits from influencing each other. The auxiliary power can be supplied via the connection terminals or type-specific via the optional In-Rail-Bus connector (see accessories).

► Configuration and startup

Configuring with DIP switch

Use the DIP switches to configure the device, according to table.

Configuring with software DRAGOset

Use the software DRAGOset to configure the device. Changes to the configuration and parameterization data can be performed both during operation with a connected measuring circuit and in a disconnected state.

The DRAGOset software is available for download free of charge at: www.drago-automation.de

The device is equipped with a programming socket on the front. Use the DRAGOset USB Converter only for connecting the device to the PC (Order no.: DZU1201). To change the configuration and parameterization DIP switch S1- 1, 2, 3 have to be set ON!

Commissioning Function

The Commissioning Function with a stepped keystone signal on output supports a fast and simple testing of cabling and connection of downstream devices or measuring adjustment. Press the function button located behind the front cover for longer than 3 seconds. The Commissioning Function will be indicated with a yellow LED (quick double off).
Output value:

Output	0 %	↗	50 %	↗	100 %	↘	50 %	↘
Time	5 s	3 s	3 s	3 s	5 s	3 s	3 s	3 s

The stepped keystone signal is output continuously. Exit the Commissioning Function by pressing the button again for 3 seconds or power off.

► Mounting, Electrical Connection

The transmitter is mounted on standard 35 mm DIN rail

Terminal assignments

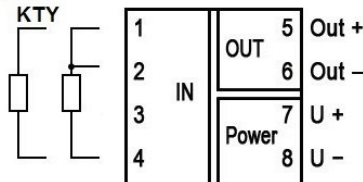

► Technical Data

Input		
Sensor		
KT100, KT110, KT130, KT210, KT230, KTY10-5, KTY10-6, KTY10-6Z, KTY10-7, KTY11-5, KTY11-6, KTY11-7, KTY13-5, KTY13-6, KTY13-7, KTY16-6, KTY19-6M, KTY19-6Z, KTY21-5, KTY21-6, KTY21-7, KTY23-5, KTY23-6, KTY23-7, KTY81-110, KTY81-120, KTY81-121, KTY81-122, KTY81-210, KTY81-220, KTY81-221, KTY81-222, KTY81-250, KTY81-251, KTY81-252, KTY82-110, KTY82-120, KTY82-121, KTY82-122, KTY82-150, KTY82-151, KTY82-152, KTY82-210, KTY82-220, KTY82-221, KTY82-222, KTY82-250, KTY82-251, KTY82-252, KTY83-110, KTY83-120, KTY83-121, KTY83-122, KTY83-150, KTY83-151, KTY83-152, KTY84-130, KTY84-150, KTY84-151, KTY84-152, ST-13, ST-15, ST-16, ST-20M, ST-20Z		
Range Setting	calibrated steps of 25 °C in complete sensor measuring ranges, configurable via DIP switch or USB interface	
Measuring span min.	25 K	
Measuring error	< 0.3 K + 0.05 % meas. val.	
Sensor connection	3-wire, 2-wire	
Sensor current	0.2 mA	
Cable resistance	< 100 Ω per wire for 3-wire connection	
Output		
Output signal	Current	Voltage
	0...20 mA	0...10 V
	4...20 mA	0...5 V
Load	≤ 12 V (600 Ω at 20 mA)	≤ 5 mA (2 kΩ at 10 V)
Residual ripple	< 10 mV _{rms}	
Transfer range	0 to 102.5 % (3.8 to 20.5 mA at output 4 to 20 mA) Transfer characteristic rising / falling	
Error signal/message	Sensor- / wire break, error signal configurable	
General data		
Transmission error	< 0.1 % full scale	
Temperature coefficient ²⁾	< 100 ppm/K	
Measurement rate	4 / s	
Response time T99	250 ms	
Test voltage	3 kV, 50 Hz, 1 min. Input against output against power supply	
Working voltage ³⁾ (basic insulation)	600 V AC/DC for overvoltage category II and contamination class 2 acc. to EN 61010-1	
Protection against dangerous body currents ³⁾	Protective Separation by reinforced insulation acc. to EN 61010-1 up to 300 V AC/DC for overvoltage category II and contamination class 2 between input and output and power supply.	
Ambient temperature	Operation -25 °C to +70 °C (-13 to +158 °F) Transport and storage -40 °C to +85 °C (-40 to +185 °F)	
Power supply	24 VDC	9.6 V ... 31.2 V, approx. 0.8 W
EMV ⁴⁾	EN 61326-1	
MTBF	353 years acc. to SN 29500 (stationary continuous operating, average ambient temperature 40 °C)	
Construction	6.2 mm (0.244") housing, protection type: IP 20 mounting on 35 mm DIN rail acc. to EN 60715	
MTBF	353 years acc. to SN 29500 (stationary continuous operating, average ambient temperature 40 °C)	
Weight	Approx. 70 g	

- 1) Factory setting:
Input: KTY100, 0...100°C, 4-wire-sensor connection
Output: 0...20 mA, Characteristic rising, error signal 22 mA
- 2) Average TC related to full scale value in specified operating temperature range, reference temperature 23 °C
- 3) As far as relevant the standards and rules mentioned above are considered by development and production of our devices. In addition relevant assembly rules are to be considered by installation of our devices in other equipment's. For applications with high working voltages, take measures to prevent accidental contact and make sure that there is sufficient distance or insulation between adjacent situated devices.
- 4) Minor deviations possible during interference

► Order Information

KTY Temperature Transmitter	Order No.
Screw terminals	DT 45600 S
Screw terminals, In-Rail-Bus	DT 45600 B
Push-In terminals	DT 45604 S
Push-In terminals, In-Rail-Bus	DT 45604 B

► Dimensions

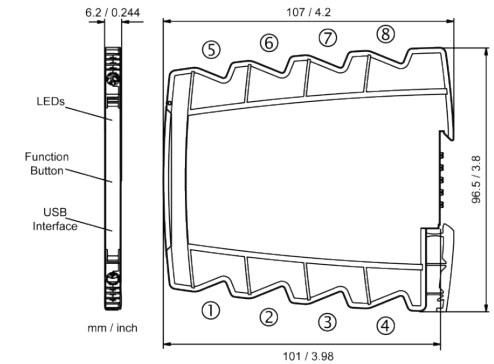

► Connection data

Connection	Screw terminals	Push-In terminals
Wire cross-section stranded ferruled	0.5 mm ² - 2.5 mm ² AWG 20 - 14	0.5 mm ² - 1.5 mm ² AWG 20 - 16
Wire cross-section solid wire	0.5 mm ² - 2.5 mm ² AWG 20 - 14	0.5 mm ² - 2.5 mm ² AWG 20 - 14
Stripped length	8 mm / 0.3 in	8 mm / 0.3 in
Screw terminal torque	0.6 Nm / 5 lbf in	-

LIMITED WARRANTY

DRAGO Automation GmbH hereby warrants that the Product will be free from defects in materials or workmanship for a period of **five (5) years** from the date of delivery ("Limited Warranty"). This Limited Warranty is limited to repair or replacement at DRAGO's option and is effective only for the first end-user of the Product. This Limited Warranty applies only if the Product:

1. is installed according to the instructions furnished by DRAGO;
2. is connected to a proper power supply;
3. is not misused or abused; and
4. there is no evidence of tampering, mishandling, neglect, accidental damage, modification or repair without the approval of DRAGO or damage done to the Product by anyone other than DRAGO.

Delivery conditions are based upon the „GENERAL CONDITIONS FOR THE SUPPLY OF PRODUCTS AND SERVICES OF THE ELECTRICAL AND ELECTRONICS INDUSTRY“ recommended by the Zentralverband Elektrotechnik- und Elektronikindustrie (ZVEI) e.V. .

Subject to change!

DRAGO Automation GmbH

Waldstrasse 86 - 90
13403 BERLIN
GERMANY

Phone: +49 (0)30 40 99 82 - 0
E-Mail: info@drago-automation.de
Internet: www.drago-automation.de

Set the input and output ranges with DIP switches (● = ON) as indicated in the following table:

DIP S1-						Input
1	2	3	4	5	6	
					●	KT210, KT230, KTY21-6, KTY23-6
●						KTY21-5, KTY23-5
	●					KTY21-7, KTY23-7
●	●					KTY81-110, KTY81-120, KTY82-110, KTY82-120, KTY82-150
		●				KTY81-121, KTY82-121
●		●				KTY81-122, KTY82-122
	●	●				KTY83-110, KTY83-120, KTY83-150
			●			KTY83-121
●			●			KTY83-122
	●		●			KTY83-151
●	●		●			KTY83-152
		●	●			KTY84-130, KTY84-150
●		●	●			KTY84-151
	●	●	●			KTY84-152
				●		KT100, KT110, KT130, KTY10-6, KTY10-62, KTY11-6, KTY13-6, KTY16-6, KTY19-6M, KTY19-6Z, ST-13, ST-15, ST-16, ST-20M, ST-20Z
●				●		KTY10-5, KTY11-5, KTY13-5
	●			●		KTY10-7, KTY11-7, KTY13-7
●	●			●		KTY81-210, KTY81-220, KTY81-250, KTY82-210, KTY82-220, KTY82-250
		●		●		KTY81-221, KTY82-221
●		●		●		KTY81-222, KTY82-222
	●	●		●		KTY81-251, KTY82-251
			●	●		KTY81-252, KTY82-252
●			●	●		KTY82-151
	●		●	●		KTY82-152
●	●	●				PC (USB) Setting
					●	2-wire
						3-wire

● = ON, Factory settings: all switches in position OFF

LED indication

The transmitter has a green and a red/yellow LED on front panel.

LED		Announcement
green	continuous	Power LED, normal operation
green	flashing	Over/under range on input
yellow	slow double flashing	Commissioning Function active
red	flashing	Sensor break
red	double flashing	Configuration error
red	continuous	Device error, replacement is necessary

Start Value					
DIP S1-					
7	8	9	10	°C	°F
●	●	●		-50	-58
			●	-25	-13
				0	32
●			●	25	77
	●		●	50	122
●	●		●	75	167
		●	●	100	212
●		●	●	125	257
●	●	●	●	150	302
●	●	●	●	175	347

End Value							
DIP S2-							
1	2	3	4	5	6	°C	°F
	●	●				-25	-13
●	●	●				0	32
			●			25	77
●			●			50	122
	●		●			75	167
						100	212
●	●		●			125	257
		●	●			150	302
●		●	●			175	347
	●	●	●			200	392
●	●	●	●			225	437
				●		250	482
●				●		275	527
	●			●		300	572

Output					
DIP S2-					
7	8	9	10		
					0 ... 20 mA
●					4 ... 20 mA
	●				0 ... 10 V
●	●				0 ... 5 V
					Characteristic
					rising
		●			falling
					Error Message
					signalize
			●		not signalize

Error diagnostic function on output

Characteristic	Error	Output	Underrange	Overrange	Sensor break / invalid setting
rising S2-9 OFF	signalize S2-10 = OFF	0 ... 20 mA	0 mA	20.5 mA	22 mA
		4 ... 20 mA	3.8 mA	20.5 mA	22 mA
		0 ... 10 V	0 V	10.25 V	11 V
		0 ... 5 V	0 V	5.125 V	5.5 V
falling S2-9 ON	signalize S2-10 = OFF	0 ... 20 mA	0 mA	20 mA	0 mA
		4 ... 20 mA	4 mA	20 mA	4 mA
		0 ... 10 V	0 V	10 V	0 V
		0 ... 5 V	0 V	5 V	0 V
falling S2-9 ON	not signalize S2-10 = ON	20 ... 0 mA	20.5 mA	0 mA	22 mA
		20 ... 4 mA	20.5 mA	3.8 mA	22 mA
		10 ... 0 V	10.25 V	0 V	11 V
		5 ... 0 V	5.125 V	0 V	5.5 V
falling S2-9 ON	not signalize S2-10 = ON	20 ... 0 mA	20 mA	0 mA	0 mA
		20 ... 4 mA	20 mA	4 mA	4 mA
		10 ... 0 V	10 V	0 V	0 V
		5 ... 0 V	5 V	0 V	0 V