

Isolation Amplifier DS 7200

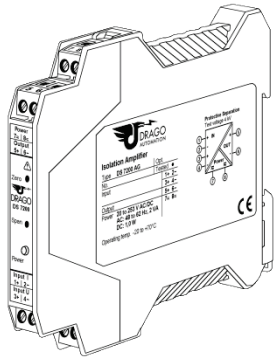

Read these instructions before using the product and retain for future information.

DS 7200

1. Before Startup



When operating the isolating amplifier, certain parts of the module can carry dangerous voltage! Ignoring the warnings can lead to serious injury and/or cause damage!

The isolation amplifier should only be installed and put into operation by qualified staff. The staff must have studied the warnings in these operating instructions thoroughly.

The isolation amplifier may not be put into operation if the housing is open. The adjustment with the potentiometer on the front may only be carried out with a screwdriver which is securely insulated against the input voltage!

In applications with high operating voltages sufficient distance and isolation as well as shock protection must be ensured.

Safe and trouble-free operation of this device can only be guaranteed if transport, storage and installation are carried out correctly and operation and maintenance are carried out with care.



Appropriate safety measures against electrostatic discharge (ESD) should be taken during range selection and assembly on the transmitter.

2. Short Description

The 3-way isolation amplifier is used for electrical isolation and conversion of bipolar and unipolar shunt voltages. Input and output range can be set by using DIP switch. The Zero/Span Adjustment on the front allows a fine-tuning of the measurement signal and the recalibration after a range selection.

The 3-way isolation guarantees reliable decoupling of the sensor circuit from the processing circuit and prevents linked measurement circuits from influencing each other. The Protective Separation with high isolation level provides protection for personnel and downstream devices against impermissibly high voltage.

3. Functioning

The input signal is modulated and then electrically decoupled using a transformer. The isolated signal is then made available at the output, demodulated, filtered and amplified.

4. Configuration

4.1 Equipment

A screwdriver with a width of 2.5 mm is required to open the unit and to connect the wires to the screw clamp terminals.

4.1 Opening The Unit

Using a screwdriver, release the snap fittings of the upper part of the housing on both sides (1). The upper part of the housing and the electronics can now be pulled out by approximately 3 cm (2).

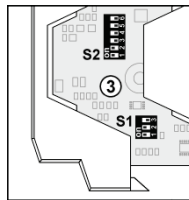
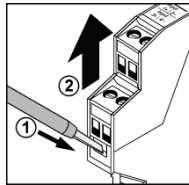

4.3 Settings

Set the input and output ranges with DIP switch (3) as indicated in the following table:

Input	Switch S1	Terminal	Output	Switch S2
	1 2 3	4 5 6		1 2 3 4 5 6
± 60 mV	● ● ●	3/4	± 10 V	● ● ● ● ● ●
0 to 60 mV	● ● ●	3/4	0 to 10 V	● ● ● ● ● ●
± 100 mV	● ● ●	1/2	2 to 10 V	● ● ● ● ● ●
0 to 100 mV	● ● ●	1/2	± 5 V	● ● ● ● ● ●
± 150 mV	● ● ●	3/4	0 to 5 V	● ● ● ● ● ●
0 to 150 mV	● ● ●	3/4	1 to 5 V	● ● ● ● ● ●
± 250 mV	● ● ●	1/2	± 20 mA	● ● ● ● ● ●
0 to 250 mV	● ● ●	1/2	0 to 20 mA	● ● ● ● ● ●
± 300 mV	● ● ●	3/4	4 to 20 mA	● ● ● ● ● ●
0 to 300 mV	● ● ●	3/4	± 10 mA	● ● ● ● ● ●
± 600 mV	● ● ●	1/2	0 to 10 mA	● ● ● ● ● ●
0 to 600 mV	● ● ●	1/2	2 to 10 mA	● ● ● ● ● ●
Zero Pot. ± 10% of range			Bandwidth 10kHz	●
Span Pot. ± 10% of range			Bandwidth 30 kHz	●

○ factory setting ● customer setting

After each range selection a Zero/Span Adjustment ought to be executed!

5. Mounting, Electrical Connection

The isolation transmitter is mounted on standard 35 mm DIN rail.

Terminal assignments			
1	Input +	5	Output +
2	Input -	6	Output -
3	Input +	7	Power supply ⊕
4	Input -	8	Power supply ⊖

6. Technical Data

Input			
Input signal	± 60 mV	0 - 60 mV	± 250 mV 0 - 250 mV
(terminal/switch selectable)	± 100 mV	0 - 100 mV	± 300 mV 0 - 300 mV
	± 150 mV	0 - 150 mV	± 500 mV 0 - 500 mV
Input resistance	> 100 kΩ		
Input capacitance	Approx. 1 nF		
Overload	Voltage limitation via 30 V Z-Diode, max. continuous current 30 mA		
Output		Voltage	
Output signal	± 10 V	± 5 V	± 20 mA ± 10 mA
(switch selectable)	0 - 10 V	0 - 5 V	0 - 20 mA 0 - 10 mA
	2 - 10 V	1 - 5 V	4 - 20 mA 2 - 10 mA
Load	≤ 10 mA (1 kΩ @ 10 V) ≤ 12 V (600 Ω @ 20 mA)		
Linear transmission range	Unipolar: -2 to + 110%		Bipolar: -110 to +110%
Ripple	< 20 mV _{rms}		
General data			
Transmission error	± 0,1 % of end value		
Temperature coefficient ²⁾	± 100 ppm/K of end value		
Zero/Span adjustment	± 10 % of end value		
Cut-off frequency (-3 dB)	> 10 kHz ³⁾ switchable to approx. 30 Hz		
Test voltage	4 kV, 50 Hz, 1 min. Input against output against power supply 5 kV, 50 Hz, 1 min. Input against output/power supply (DS7200HV only)		
Working voltage ³⁾	1000 V AC/DC for overvoltage category II and contamination class 2 acc. to EN 61010 part 1		
(Basic insulation)	Protection against dangerous body currents ³⁾ Protective Separation by reinforced insulation acc. to EN 61010 part 1 up to 600 V AC/DC for overvoltage category II and contamination class 2 between input and output and power supply.		
Ambient temperature	Operation - 20 °C to + 70 °C (-4 to 158 °F) Transport - 35 °C to + 85 °C (-31 to 185 °F) and storage		
Power supply	20 to 253 V AC/DC AC 48 ... 62 Hz, approx. 2 VA DC approx. 1,0 W		
EMC ³⁾	EN 61326 -1		
Construction	12,5 mm (0.5") housing, protection type: IP 20		
Connection	pluggable screw connection solid/stranded 0.2 to 2.5 mm ² , AWG 24 to 12 tightening torque 0.5 to 0.6 Nm		
Weight	Approx. 100 g		

- factory setting: Input: ± 60 mV, Output: ± 10 V
- Average TC in specified operating temperature range
- As far as relevant the standards and rules mentioned above are considered by development and production of our devices. In addition relevant assembly rules are to be considered by installation of our devices in other equipments. For applications with high working voltages, take measures to prevent accidental contact and make sure that there is sufficient distance or insulation between adjacent situated devices.
- Minor deviations possible during interference

7. Block Diagram

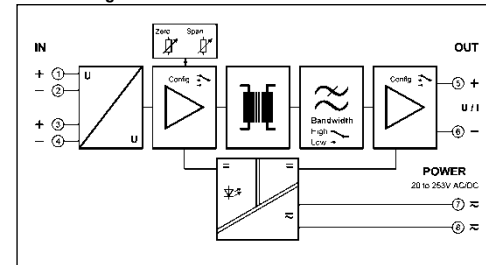

8. Order Information

Product	Input / Output	Part No.
Isolation Amplifier	configurable	DS 7200 AG
Isolation Amplifier, 5 kV	configurable	DS 7200 HV

9. Dimensions

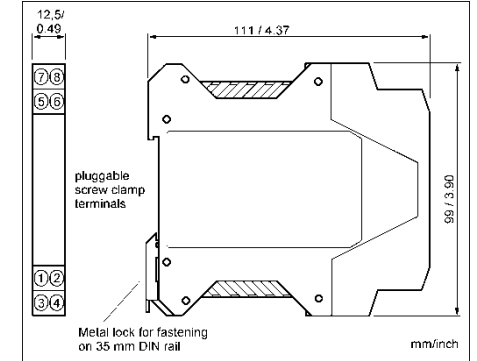

LIMITED WARRANTY

DRAGO Automation GmbH hereby warrants that the Product will be free from defects in materials or workmanship for a period of five (5) years from the date of delivery ("Limited Warranty"). This Limited Warranty is limited to repair or replacement at DRAGO's option and is effective only for the first end-user of the Product. This Limited Warranty applies only if the Product:

- is installed according to the instructions furnished by DRAGO;
- is connected to a proper power supply;
- is not misused or abused; and
- there is no evidence of tampering, mishandling, neglect, accidental damage, modification or repair without the approval of DRAGO or damage done to the Product by anyone other than DRAGO.

Delivery conditions are based upon the „GENERAL CONDITIONS FOR THE SUPPLY OF PRODUCTS AND SERVICES OF THE ELECTRICAL AND ELECTRONICS INDUSTRY“ recommended by the Zentralverband Elektrotechnik- und Elektronikindustrie (ZVEI) e.V. .

Subject to change!

DRAGO Automation GmbH

Waldstrasse 86 - 90
13403 BERLIN
GERMANY

Phone: +49 (0)30 40 99 82 - 0
Fax: +49 (0)30 40 99 82 - 10

E-Mail: info@drago-automation.de
Internet: www.drago-automation.de